



KODIAK K6 TFFV TRACKED FIREFIGHTING VEHICLE CARRIER SPECIFICATIONS

<u>DIMENSIONS / WEIGHT</u>		<u>FRAME / SUSPENSION</u>	
Overall length	193" without plow 229" with plow	Type	Corten Welded Tub
Overall width	100" with plow 96" without plow & mirrors	Suspension system:	
Overall height	106"	➤	Patented walking beam with double twin rocker bogey wheel suspension
Ground clearance	21"	➤	2 independent idler wheels with oil bath hubs and steel face seals
Fording	13,080 lbs base vehicle	➤	2 rear drive sprockets
Weight	32"	➤	16 steel wheels, 12" dia
Typical options with fire package dry	16,075 lbs	<u>POWER TRAIN FOR HYDROSTATIC DRIVE</u>	
GVWR	24,000 lbs max	Transmission	Hydrostatic, 2-speed
<u>PERFORMANCE</u>		Service Brakes	Positive deceleration through the hydrostatic transmission
Maximum speed	8 mph loaded	Parking brakes	Multi-Disc, spring applied & pressure released
Inside turning radius	0 ft	<u>ELECTRICAL</u>	
Ground pressure (6" penetration)	2.32 PSI base vehicle	Voltage	12 V
Typical options with fire package (dry)	2.86 PSI	(2) batteries, capacity	1,000 CCA
Maximum gradeability	Static test when loaded	Alternator capacity	120 Amps
- Uphill	35° (70%) continuous	Ground	Negative
- Side-hill	15° (27%)	<u>TRACKS</u>	
Angle of approach	35° (70%) without plow	One piece 24" rubber tracks with steel reinforcements	
" " departure	40° (84%)	<u>TRACK TENSIONING</u>	
Normal driving range	12 hours	Active tensioning maintains track tension & compensates as the walking beam position changes while traversing different slopes and terrains	
<u>ENGINE</u>		<u>STEERING</u>	
Make	Deutz AG Tier 4	Independent dual joysticks with cable control for each track	
Model	TCD 3.6 L4, 4 cylinder Turbo charged diesel	<u>STANDARD FEATURES</u>	
Horsepower	134 HP at 2,300 RPM	12v primary fuel filter heater, secondary fuel filter with water separator	
Torque	369 ft lbs at 1,600 RPM	Hydraulic oil tank cooler	
Displacement	3.6 liters	Fire extinguisher	
Fuel capacity	50 gals	Backup alarm and horn	
DEF tank	2.6 gals	Removeable cab entrance steps	
Cooling system	4.0 gals	2x side deck ladders	
		1 set of operations, parts & service manuals	
		Standard one-year warranty	

*Specifications subject to change without notice.





KODIAK K6 TFFV TRACKED FIREFIGHTING VEHICLE FIRE PACKAGE SKID SYSTEM OPTIONS

Skid System Engine:	Gasoline powered - standard	
	Diesel powered - option upon request	
Medium Flow Skid System:	<p>23 HP engine, 300 gallon water tank, 10 gallon foam cell (optional gel concentrate line) 3" Flange Tank to pump, 1" Tank Fill Flange, 1" Foam Flange, 8" Water Tower with Lid, 8" Foam Tower with Lid Manifold for 1" (provision for reel) and 2 X 1.5" Handlines. Tridents brand 3 piece drop out valves. ¼ turn ball valves used Centrifugal pump capable of flowing 130gpm at 130psi, Two 1.5" outputs, One 2.5" drafting inlet 1200 PSI UHP Hose Diameter: 12 GPM UHP Hose Length: 150'. 150 PSI Centrifugal Output: 10 PSI Standard firefighting nozzles (select or automatic gallons) Max Output: 285 GPM. Centrifugal Draft: 95 inches. Pump to Tank: 48 inches. Tank to Pump: 42 Inches Mini Control panel with Choke control, vernier throttle, low engine oil light</p>	
Low Pressure System:	<p>23 HP engine, 500 gallon water tank, Integrated 10 gallon foam cell, Water pump: low pressure centrifugal, Foam system; eductor type .1-3% Hose reel: 1" high pressure hose reel x 100' Nozzle: manually operated low pressure pistol grip style fog nozzle Pump control panel with LED 12 volt light, Drafting capable</p>	
	Low pressure/high volume flow rates:	<p>274 gpm at 50 psi 220 gpm at 100 psi 112 gpm at 150 psi</p>
Low Pressure System with CAFS:	<p>31 HP engine, 500 gallon water tank, Integrated 10 gallon foam cell Water pump: single-stage centrifugal: 250 gpm at 40 psi, 120 gpm at 100 psi Electric rewind reel 100' X 1" with smooth bore nozzle Pump control panel with LED 12 volt light Performance: 120 gpm & 50 cfm at 100 psi, Drafting capable</p>	
Switchable High Pressure/Ultra-High Pressure System:	<p>35 HP engine, 500 gallon water tank, Integrated 10 gallon foam cell Class A foam eductor UHPS, Electric hose reel ultra high pressure ¾" x 200' Water pump: high pressure positive displacement piston Nozzle: manually operated pistol grip high pressure Ultra high pressure nozzle: one 20 gpm wand fog nozzle Pump control panel with LED 12 volt light, High pressure output: 25 gpm at 700 psi Ultra-High Pressure output: 20 gpm at 1,400 psi, Drafting capable</p>	
Ultra High Pressure Pyrolance System (HY/LO):	<p>35 HP engine, 500 gallon water tank, Integrated 10 gallon foam cell, Two independent pumps, Class A foam eductor UHPS, Ultra-high pressure electric hose reel and attack hose, Water pump: high pressure positive displacement piston Nozzle: manually operated pistol grip high pressure Ultra high pressure nozzle: one 20 gpm wand fog nozzle Pump control panel with LED 12 volt light HY characteristics: (Outputs #1 & #2 selectable via electric switch when valve on HY mode). Output #1: 20 gpm @ 1400 psi, Output #2: 25 gpm @ 700 psi Hose: 0.75" (3/4") diameter, rigid, on reel, 200' length (quick-connect extensions avail) LO characteristics: (Output #3 selectable via setting mechanical valve to LO mode). Output #3: 100 gpm @ 100 psi, Hose: 1.5" diameter, flat-lay, 200' length Drafting capable</p>	
Note: The packages above are baseline packages, substitutions may be possible, call for details.		
Water Tank	Change 500 gallon to 300 gallon water tank	
GFS 75 Terra Torch	<p>12-volt GFS GelGun, 20-foot GelHose system 12-volt enclosed control box, Honda GX160-LX2 gas motor</p>	



KODIAK K6 TFFV CRAWLER CARRIER OPTIONS & ACCESSORIES

Front Vehicle Options

Heavy duty lower front brush guard with skid plate
2 way medium duty front plow for pushing loose fill
16,500 lbs electric winch with remote control (wired, 12 ft lead)
18,000 lbs hydraulic winch with in cab controls

Cab Options

Driver's wire mesh screen (1-man open cab)
Driver's left side wire mesh door and side wall (open cab)
Steel escape hatch for open or closed cab (adds FOPS certification)
Cab mounted front brush guard for 1-man closed cab
Three-point grab handles for cab and deck access
1 Man Closed Cab ROPS certified includes: Aluminum escape hatch Sliding left & right side window Cab heater & circulation fan Front windshield on/off wiper & windshield washer Door with dual locking system
Cab mount front brush guard for 2-man cab (open or closed)
Two Man Open Cab ROPS certified includes: 2 vinyl mechanical suspension seats with slider with 2 point seat belts, 1 rearview mirror
Two Man Closed Cab ROPS certified includes: Aluminum escape hatch, 2 vinyl mechanical suspension seats with slider with 2 point seat belts Sliding left & right side window, cab heater & circulation fan, Front windshield on/off wiper & windshield washer, door with dual locking system 1 rearview mirror
Front windshield intermittent wiper (closed cab)
Steering wheel system (mechanical steering with foot pedals for forward and reverse)
Sun visor
Driver's air suspension seat
Driver's 3 point seat belt
Premium cab sound and heat Insulation
Street side and / or curb side rear view mirror
Street side rear view mirror with electric heating
Back up camera with heated lens and 7" in-cab waterproof display
DC Comfort air conditioning 6,000 Btu/hr, 12v for 1-man cab
Air conditioning 12,000 Btu/hr, 12v for 2-man cab
Cab front windshield spray system

Lighting Options

GoLight Stryker spotlight on top of cab with guarding, in cab & hand held remote control
2x 120 watts LED light bars for 1 man cab (behind the cab, swiveling, one fixed over the engine cover)

KODIAK K6 TFFV CRAWLER CARRIER OPTIONS & ACCESSORIES Cont'd

Engine & Cold Weather Options

Spark arrestor
12v engine coolant heater, 17,000 Btu with 7 day programmable timer
120v hydraulic oil tank heater
120v battery charger
Synthetic engine oil
Winter bridge & engine cover
Insulated battery box
Coolant battery heater
120v battery heaters
Glycol coolant
Synthetic hydraulic oil
1,800 watt gas powered portable generator / inverter with on deck storage

Vehicle Options / Features

Flatbed deck 96"W x 96"L
Flatbed deck 92"W x 108"L
Non slip coating on deck
FireBozz Mini Portable Water Cannon
Rear auxilliary 2-way low flow hydraulics, 0-24 GPM, 2,500 psi
Rear auxilliary 2-way low flow hydraulics, 25 GPM, 3,000 psi
Pintle hook with rear receptacle
Maintenance kit (high performance filter set for first 100 hour maintenance: return, supercharge & 2x drive pump charge filters)
Additional set of operations, parts & service manuals

Additional Options

Extra set one piece 24" rubber tracks with steel reinforcements (shipped loose)
One day on site Kodiak K6 operations and maintenance training
One day on site fire package skid system training
One day on site GFS Terra Torch training
Recommended spare parts for remote operations

Other options available upon request

KODIAK K6 TFFV CRAWLER CARRIER DIMENSIONS

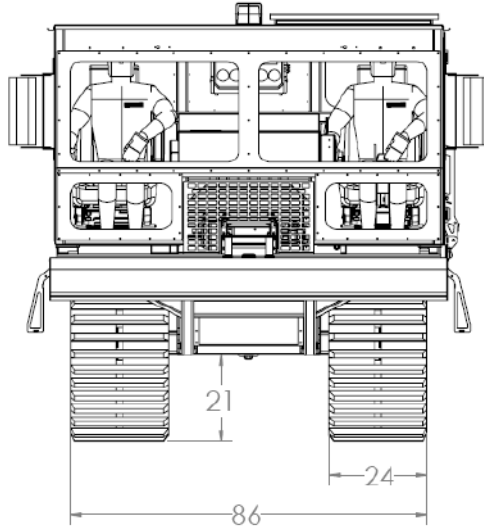

KODIAK K6 TFFV CRAWLER CARRIER DIMENSIONS

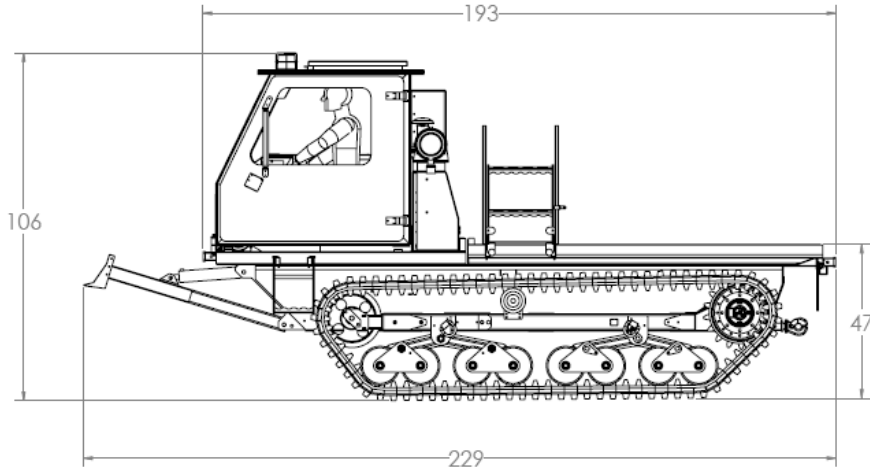

UTV INTERNATIONAL KODIAK K6 TFFV CRAWLER CARRIER

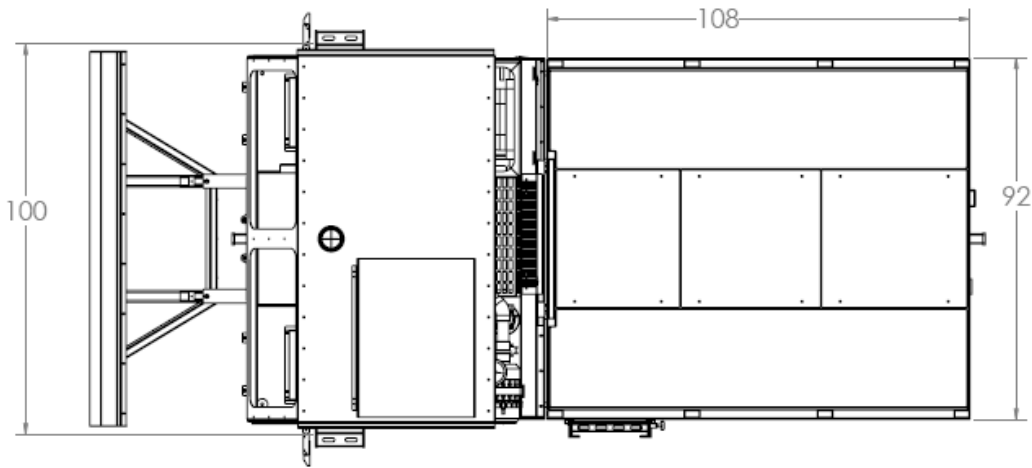

KODIAK K6 TFFV CRAWLER CARRIER

